

DUAL BNC WITH CAPACITOR FILTERING RIGHT ANGLE

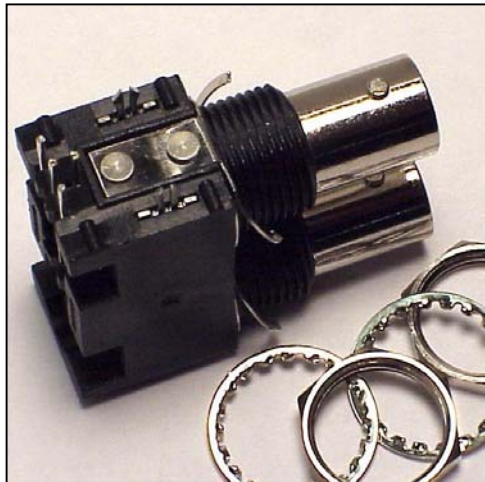

RoHS Compliant



BNC 31202F-HB-50R 50 Ohms
BNC 31202F-HB-75R 75 Ohms

MATERIAL:

- Insulator: Polypropylene UL 94HB
- Contacts: Gold Plated
- Housing: UL:94V-0 PBT
- Operating Temperature: -55°C to +85°C
- Ceramic Chip Capacitor: 4700 Pico Farad

ELECTRICAL:

- Impedance: 50 or 75 ohms
- Frequency range: 0 ~ 1.0 GHz
- Return loss: -30dB Min. / 750MHz
- Operating Voltage: 500 VRMS
- Dielectric withstanding voltage: 1500VRMS
- Insulation resistance: 5000 MegOhms Minimum

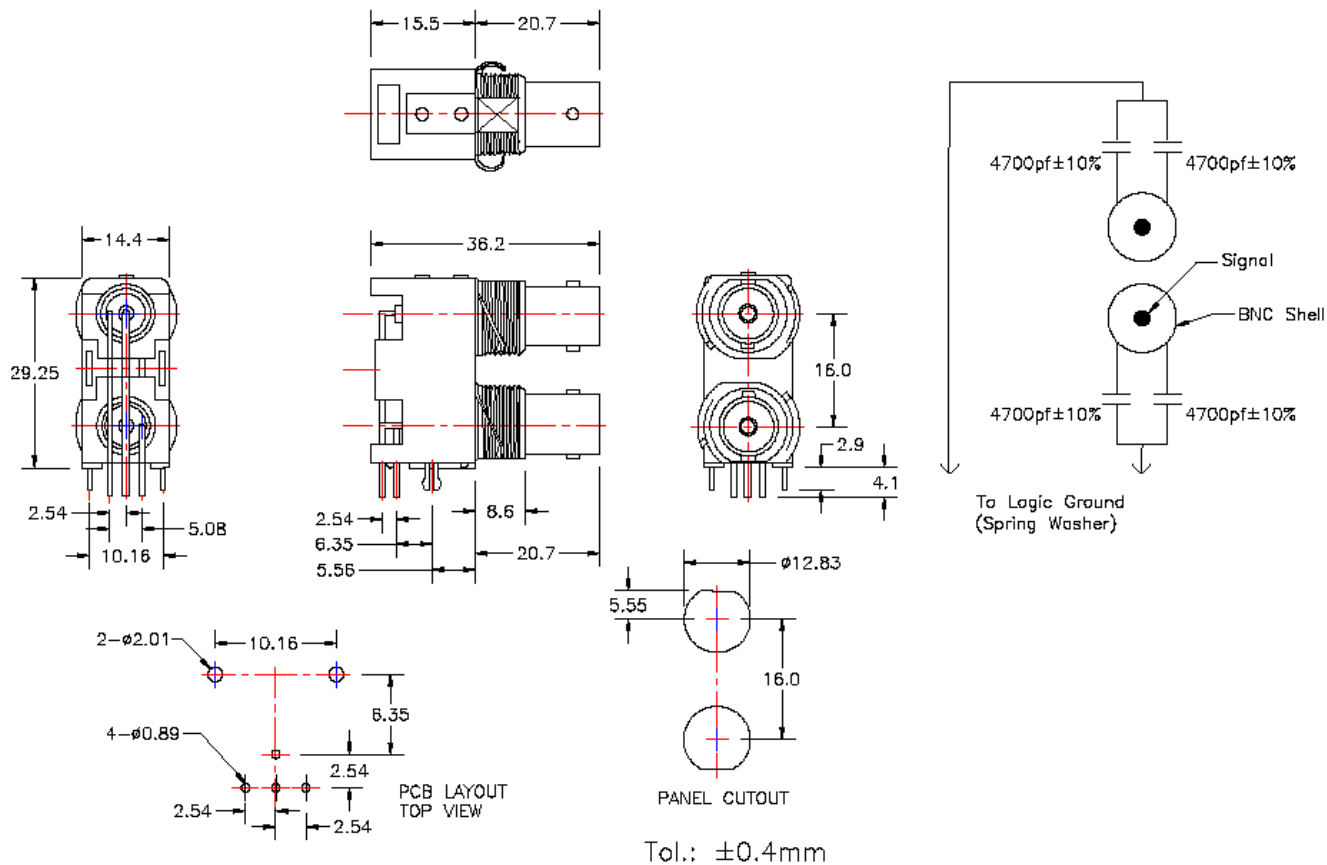

080125

120 San Lucar Court Sunnyvale, CA 94086
 Visit www.regalusa.com

Phone 800/882-8086
 E-mail hal@regalusa.com

Fax 800/345-2831